

PTH

STABI CRUSHER

Proff-kvalitet i teknikk og holdbarhet



www.pthproducts.com

- Arbeitsdybde inntil 600mm
- Blandeffekt til 800 m³/t.
- Knuser granittsteiner med en kantlengde til 600 mm.

Anvendelse i den hardeste stein



Designed for knusing og blanding av den hardeste stein, ubetydelig slitasje og høyeste levetid

Den mest moderne, robuste teknikk



Knuse- og blanderom, utrustet med utskiftbare panserplater.



Hydraulisk justerbar knuselist fra 50mm - 350mm.



Designed for hardeste stein, ubetydelig slitasje og høyeste levetid og store ytelser

Perfekte blanderesultater også ved vanskelige vilkår

Slitasjeverktøy: konstruert for høy knuse- og blandeytelse med ekstremt liten slitasje

Færre grep ved service

Slitasjedeler hurtig utskiftbar



PTH Teknikk for den perfekte maskinkontroll

av samtlige fortrolige maskindata og avrop og innstillinger foretas over **PTHtronic**®. Alle automatikkfunksjoner blir også innstilt over terminalen.





PTH stabi crusher	15500
Bygningsmetode:	Største robuste knuser i fullrammebygningsmetode vridningsfri og av høykvalitet herdet stål
Drift:	begge sider med 12 høyeffektkileremmer
Egenvekt:	16.500 kg
Rotormasse:	5.500 kg
Arbeidsbredde:	2.000 mm
Arbeidsdybde:	max. 600 mm
Kraftbehov:	min. 250 HK
Driftskapasitet:	inntil 800 m ³ /t.
1. Knusegrad:	Hydraulisk stillbar: 50 - 350 mm
	Indre slidedeler er med få håndgrep utbyttbar
Opsjon:	Fullautomatisk innsprøytningsystem Sidenivillering fullautomatikkdrift Fresemeisler for asfaltforknusing

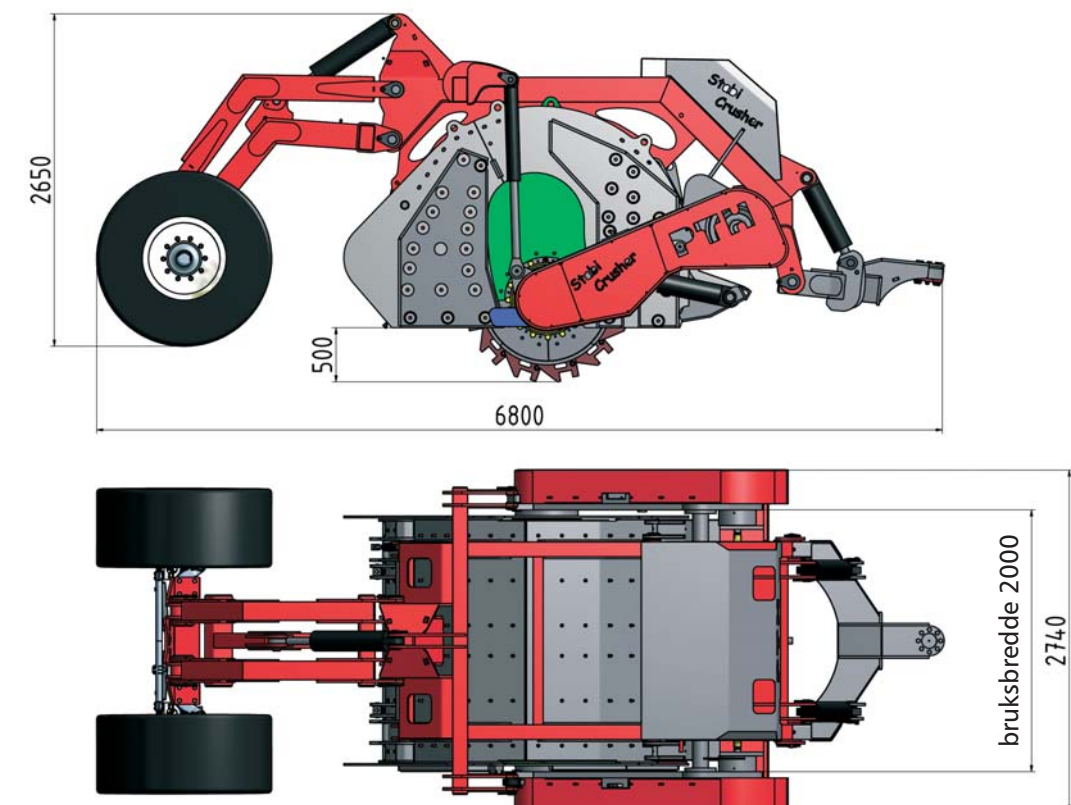

PTH

products

PTH products maskiner er i bruk over hele verden under de vanskeligste arbeidsbetingelser.



Vi leverer know-how med over 20 års erfaring innen maskin- og veibyggning.



PTH
STABI CRUSHER

PTH
CRUSHER



PTH
RIPPER



PTH
SPEED GRADER



PTH
COMPACTOR



PTH

products

Profiteam Holzer Ges.m.b.H
Lechen 14
8692 Neuberg/Mürz (Austria)
phone: +43 (0)3857 80530-0
fax: +43 (0)3857 80530-4
e-mail: office@pthproducts.com



www.pthproducts.com